



PAPI

PRECISION APPROACH PATH INDICATOR

The LED PAPI is the most advanced on the market and has the widest range of configurations:

- Visible and IR output
- Portable and permanent
- ICAO / FAA / STANAG Compliant
- Several power options

Applications

Permanent airfields
Temporary airfields
Emergency airfields
Military & NVG operations

Advanced Optics

The PAPI and the Abbreviated PAPI (APAPI) use patented, LED-based optics to achieve the lowest power consumption, highest intensity and sharpest white/red transition. It exceeds ICAO / FAA / STANAG requirements to provide a clear approach path to the aviator.

Easy Installation

The PAPI works equally well in permanent or temporary locations. Permanent mounting is easy with standard frangible mounting. Temporary deployment is fast with retractable legs and a lightweight, compact form factor.

Power Supply Versatility

The low power consumption of the PAPI makes it mate well with several available power supplies:

- Solar kit
- Generator kit
- Battery kit
- AC only

Controllable

Optional wireless control provides on-demand operation from up to 4 km (2.5 m) away. There is also 3 and 5-step, wired control and local control available.

Trusted

Deployed around the globe, from military to civilian airfields and from the Middle East to the Arctic Circle, the PAPI has proven it is robust. LED keypad and LED indicators designed for use with gloves. Removable, replaceable antenna.

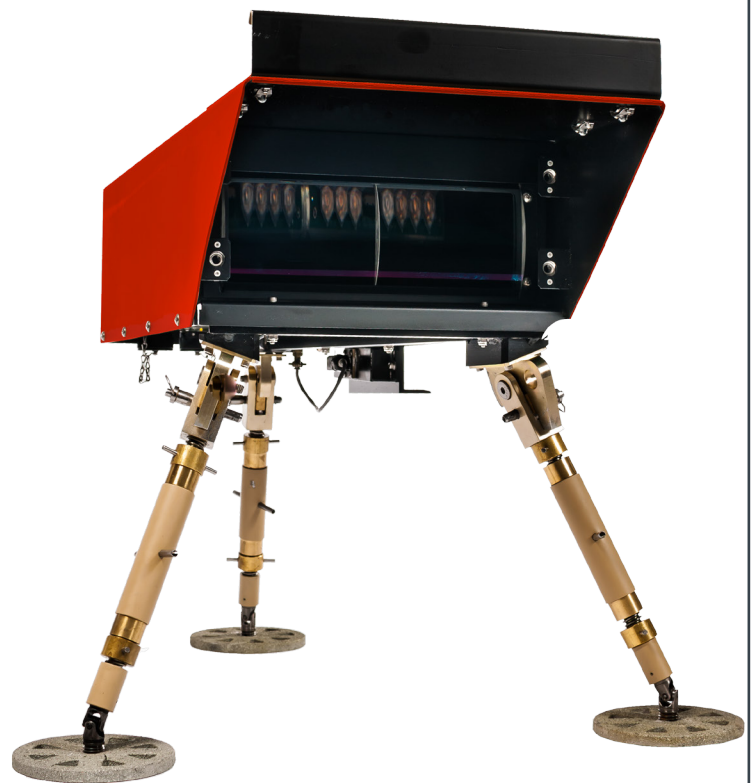

REPRESENTED IN YOUR REGION BY:

LED  Airport Lighting

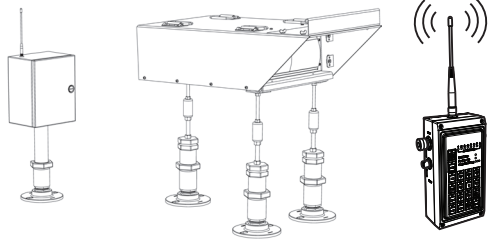

CONTROL BOX LIGHT HOUSING ASSEMBLY (LHA) OPTIONAL HANDHELD CONTROLLER

- 4 km (2.5 m) control range
- 900 MHz with encrypted signal
- Control 8 groups of lights independently

PAPI

PRECISION APPROACH PATH INDICATOR

SPECIFICATIONS

Optical	High-power LEDs with proper heat management ensure consistent photometrics for life of product
	NVG-compatible infrared (IR) LEDs
	FAA L-880/881 & E-3007 (2 & 4 LHA) compliant
	ICAO Annex 14 PAPI (2 & 4 LHA) & APAPI (2 LHA) compliant
	STANAG 3316 PAPI (2 & 4 LHA) & APAPI (2 LHA) compliant
	UFC 3-535-01 (4 LHA) compliant
Power Options	Solar kit: Solar panels and mounting, batteries and enclosures; air transportable container; AC input for backup
	Generator kit: Gas or diesel generator; AC input for backup
	Battery kit: Batteries & enclosures; AC input for backup
	AC only: 100 – 240 VAC 50/60 Hz; 3 and 5-step current input
Control Options	Non-Wireless: AC input of 3 and 5-step current; local control
	Wireless: 4 km (2.5 m) control range with optional Handheld Controller; local control
Construction	Powder coated aluminum chassis with integrated handles
	Aviation orange standard, yellow and other colors available
	Stainless steel and anodized aluminum hardware
	Integrated digital level
Temperature	-35 to 55 °C (-31 to 131 °F) ambient
Wind Loading	161 kph (100 mph)
Ingress	NEMA 4 & EN 60529 IP 55

DIMENSIONS

PERMANENT

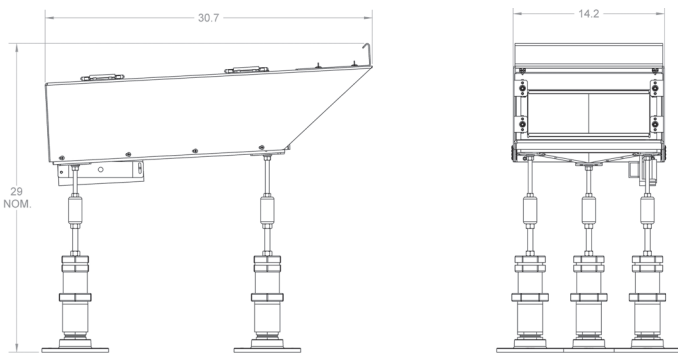

PORTABLE

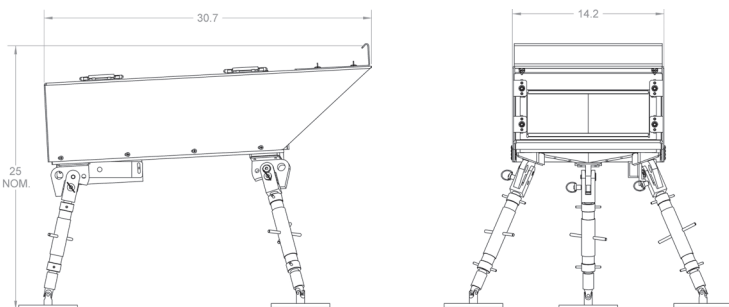

PHOTOMETRICS

PAPI ISOCANDELA

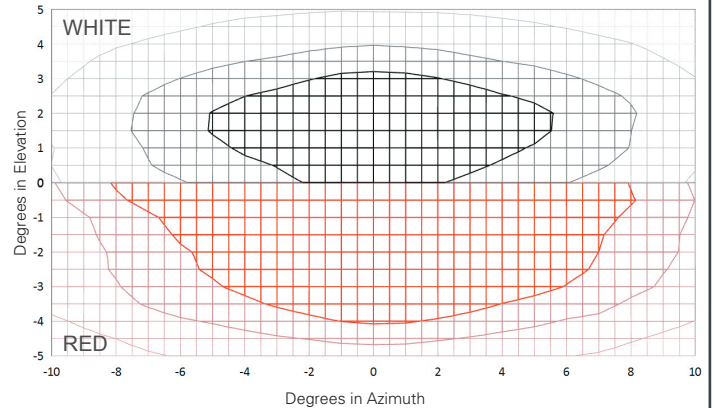

WHITE (cd)

- 0 - 10000
- 10000 - 20000
- 20000 - 30000
- 30000+

RED (cd)

- 0 - 5000
- 5000 - 10000
- 10000 - 15000
- 15000+



CONFIGURATION

MODEL	SIZE ▼	MOUNTING ▼	OUTPUT ▼	POWER ▼	CONTROL ▼
PAPI	ABBREVIATED 2 LHA STANDARD 2 LHA STANDARD 4 LHA	PERMANENT PORTABLE	VISIBLE VISIBLE/IR	SOLAR KIT GENERATOR KIT BATTERY KIT AC	NON-WIRELESS WIRELESS WIRED, STYLE B

Options: carrying case, tactical battery pack, tilt switch (for FAA), low temperature arctic kit, custom chassis color



Specifications subject to local environmental conditions.

Specifications may be subject to change.

Carmanah is a Canadian public corporation - TSX:CMH

© 2015, Carmanah Technologies Corp.

Document: AVIA_PAPI_Spec_Sheet_RevD

US and International patents apply. Other patents pending.
"Carmanah" and Carmanah logo are trademarks of Carmanah Technologies Corp.